

Identification	Cross-section mm ²	Part number		Drawing	Dimensions in mm
		Male contact	Female contact		

Han® TC 350 PE

Crimp contact



35

09 11 000 6172

09 11 000 6272

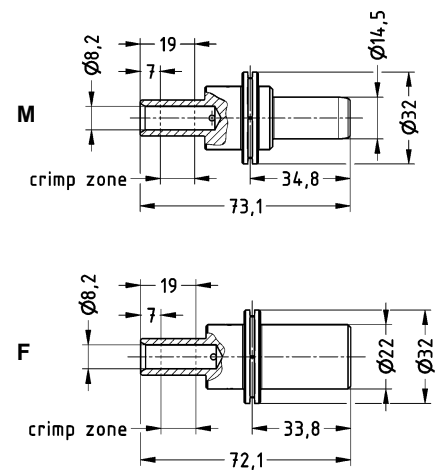

Cross-section	Tool identification	Stripping length	Ø
35 mm ²	12	26 mm	8.2 mm
For stranded wire according to IEC 60 228 Class 5			

Han® TC 350 PE

Screw contact



≤ 120

09 11 000 6158

09 11 000 6258

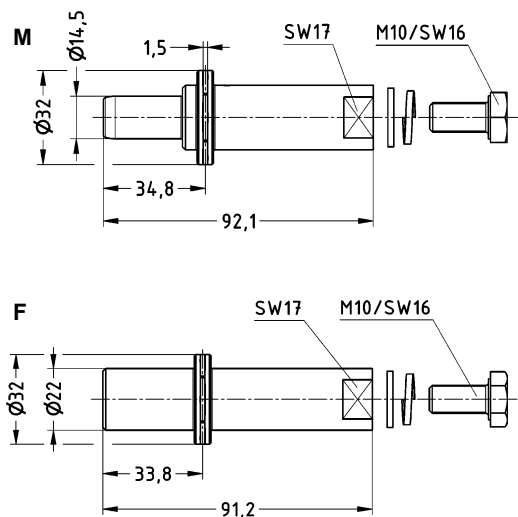

Tightening torque 14 Nm
for cable shoes ≤ 120 mm²
While applying the tightening
torque please hold the
contact with screw driver 17